

Please check the examination details below before entering your candidate information

Candidate surname

Other names

Centre Number

Candidate Number

Pearson Edexcel International GCSE

Friday 19 May 2023

Morning (Time: 2 hours)

Paper
reference

4MA1/1HR

Mathematics A

PAPER 1HR

Higher Tier



You must have: Ruler graduated in centimetres and millimetres, protractor, pair of compasses, pen, HB pencil, eraser, calculator. Tracing paper may be used.

Total Marks

Instructions

- Use **black** ink or ball-point pen.
- **Fill in the boxes** at the top of this page with your name, centre number and candidate number.
- Answer **all** questions.
- Without sufficient working, correct answers may be awarded no marks.
- Answer the questions in the spaces provided
– *there may be more space than you need.*
- **Calculators may be used.**
- You must **NOT** write anything on the formulae page.
Anything you write on the formulae page will gain **NO** credit.

Information

- The total mark for this paper is 100.
- The marks for **each** question are shown in brackets
– *use this as a guide as to how much time to spend on each question.*

Advice

- Read each question carefully before you start to answer it.
- Check your answers if you have time at the end.

Turn over ►

P72792A

©2023 Pearson Education Ltd.

N:1/1/1/1/1/



P 7 2 7 9 2 A 0 1 2 8



Pearson

International GCSE Mathematics

Formulae sheet – Higher Tier

Arithmetic series

Sum to n terms, $S_n = \frac{n}{2} [2a + (n-1)d]$

Area of trapezium = $\frac{1}{2}(a+b)h$

The quadratic equation

The solutions of $ax^2 + bx + c = 0$ where $a \neq 0$ are given by:

$$x = \frac{-b \pm \sqrt{b^2 - 4ac}}{2a}$$

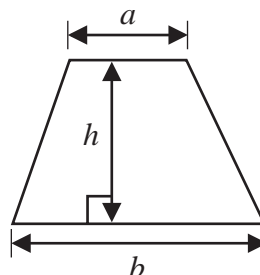
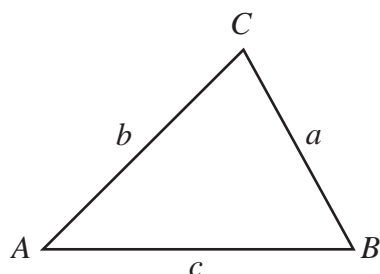
**Trigonometry**

In any triangle ABC

Sine Rule $\frac{a}{\sin A} = \frac{b}{\sin B} = \frac{c}{\sin C}$

Cosine Rule $a^2 = b^2 + c^2 - 2bc \cos A$

Area of triangle = $\frac{1}{2}ab \sin C$

Volume of cone = $\frac{1}{3}\pi r^2 h$

Curved surface area of cone = $\pi r l$

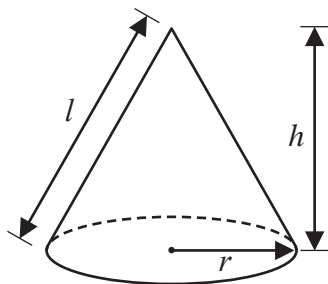

Volume of prism

= area of cross section \times length

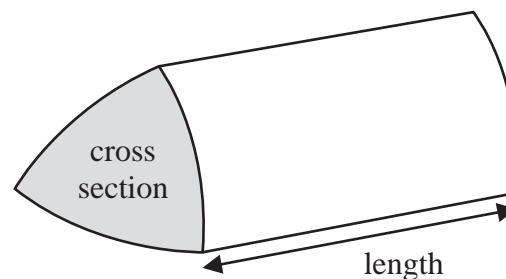

Volume of cylinder = $\pi r^2 h$

Curved surface area of cylinder = $2\pi r h$

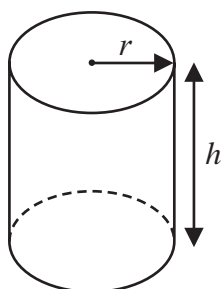

Volume of sphere = $\frac{4}{3}\pi r^3$

Surface area of sphere = $4\pi r^2$

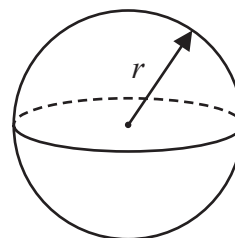

DO NOT WRITE IN THIS AREA

DO NOT WRITE IN THIS AREA

DO NOT WRITE IN THIS AREA



Answer ALL TWENTY FIVE questions.

Write your answers in the spaces provided.

You must write down all the stages in your working.

- 1 Write 2250 as a product of powers of its prime factors.
Show your working clearly.

.....
(Total for Question 1 is 3 marks)

DO NOT WRITE IN THIS AREA

DO NOT WRITE IN THIS AREA

DO NOT WRITE IN THIS AREA



2 Here is a Venn diagram.

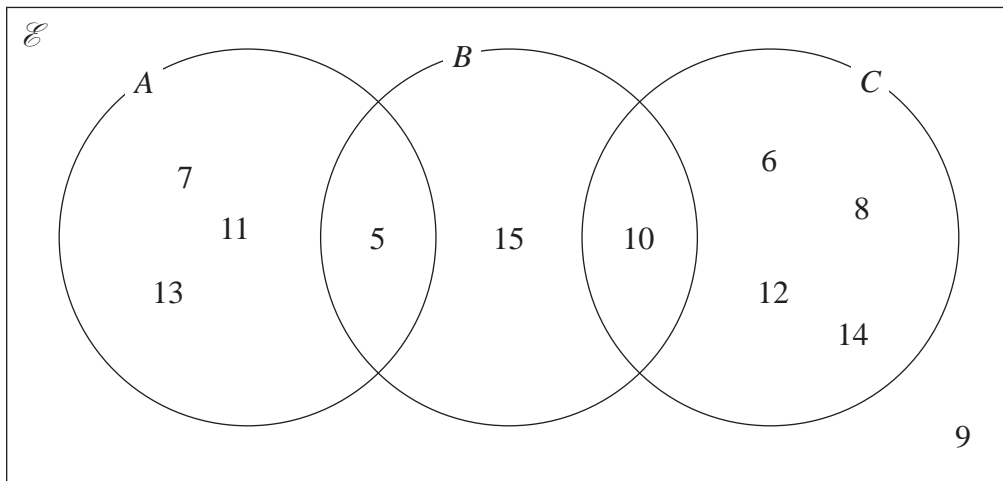

(a) Write down the numbers that are in the set

(i) A

..... (1)

(ii) $B \cup C$

..... (1)

Dominic writes down $9 \notin C$

(b) Explain why Dominic is correct.

.....
 (1)

(Total for Question 2 is 3 marks)

DO NOT WRITE IN THIS AREA

DO NOT WRITE IN THIS AREA

DO NOT WRITE IN THIS AREA



DO NOT WRITE IN THIS AREA

DO NOT WRITE IN THIS AREA

DO NOT WRITE IN THIS AREA

3 $ABCD$ and $EFGH$ are similar quadrilaterals.

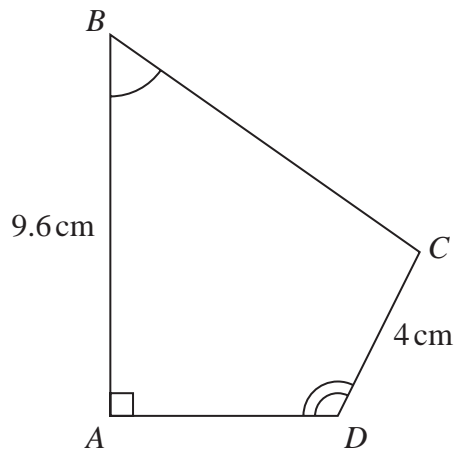
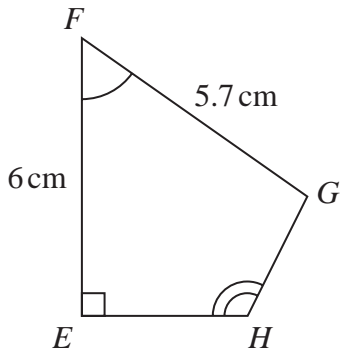

Diagram **NOT** accurately drawn



(a) Work out the length of GH

..... cm
(2)

(b) Work out the length of BC

..... cm
(2)

(Total for Question 3 is 4 marks)



- 4 The diagram shows a shape made up of three semicircles, enclosing a right-angled triangle.

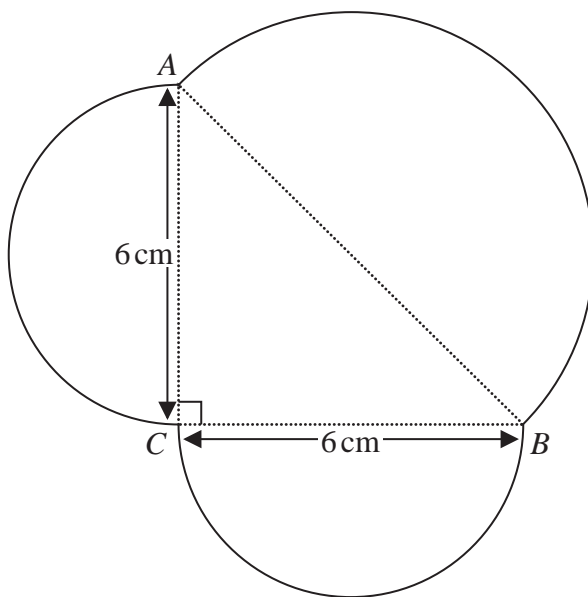

Diagram NOT accurately drawn

AB , BC and CA are each the diameter of a semicircle.

$BC = CA = 6\text{ cm}$.

Work out the perimeter of the shape.
Give your answer correct to one decimal place.

..... cm

(Total for Question 4 is 5 marks)

DO NOT WRITE IN THIS AREA

DO NOT WRITE IN THIS AREA

DO NOT WRITE IN THIS AREA



- 5 Each time Evie plays a game against her computer, she will win or lose.

For each game, the probability that Evie will win is 0.74
Evie is going to play 300 games against her computer.

Work out an estimate for the number of games that Evie will lose.

.....
(Total for Question 5 is 2 marks)

- 6 (a) Simplify $m^{10} \div m^3$

.....
(1)

$$k^n \times k^4 = k^{12}$$

- (b) Write down the value of n

$n =$
(1)

- (c) Simplify $(3x^6y^8)^2$

.....
(2)

(Total for Question 6 is 4 marks)

DO NOT WRITE IN THIS AREA

DO NOT WRITE IN THIS AREA

DO NOT WRITE IN THIS AREA



7 (a) Expand $4x(x - 5)$

.....
(1)

(b) Factorise $y^2 - 9y + 20$

.....
(2)

(Total for Question 7 is 3 marks)

8 (a) Write 5.6×10^{-3} as an ordinary number.

.....
(1)

(b) Work out $\frac{6 \times 10^3}{2.1 \times 10^{-4} + 9 \times 10^{-5}}$

Give your answer in standard form.

.....
(2)

(Total for Question 8 is 3 marks)

DO NOT WRITE IN THIS AREA

DO NOT WRITE IN THIS AREA

DO NOT WRITE IN THIS AREA



- 9 Kazi buys a car for 700 000 taka.
The value of the car depreciates by 12% each year.

Work out the value of the car at the end of 3 years.
Give your answer correct to the nearest taka.

..... taka

(Total for Question 9 is 3 marks)

DO NOT WRITE IN THIS AREA

DO NOT WRITE IN THIS AREA

DO NOT WRITE IN THIS AREA



10

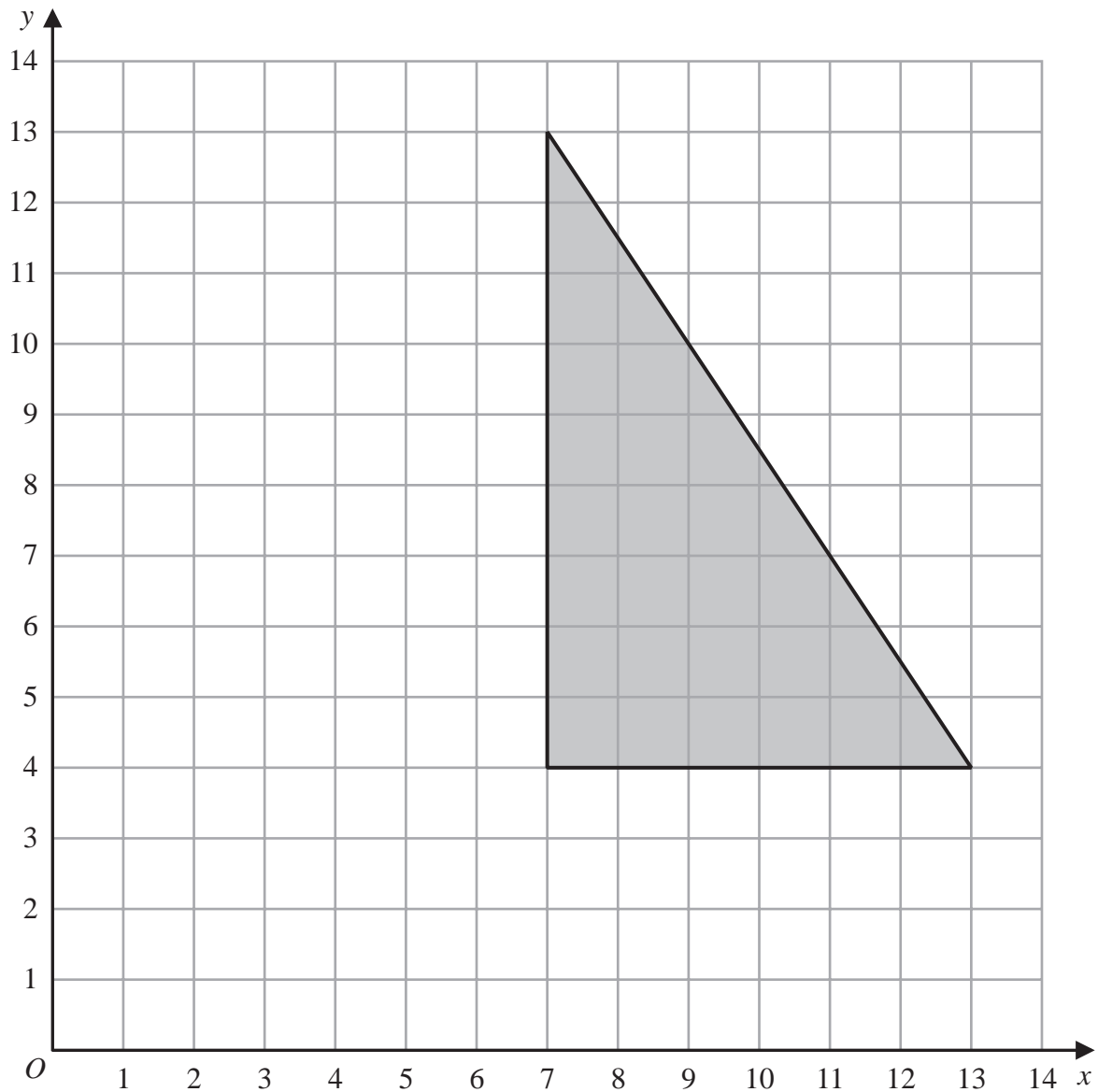

DO NOT WRITE IN THIS AREA

DO NOT WRITE IN THIS AREA

DO NOT WRITE IN THIS AREA

On the grid, enlarge the shaded shape with scale factor $\frac{1}{3}$ and centre (1, 7)

(Total for Question 10 is 2 marks)



- 11 The diagram shows a block of iron in the shape of a cuboid.

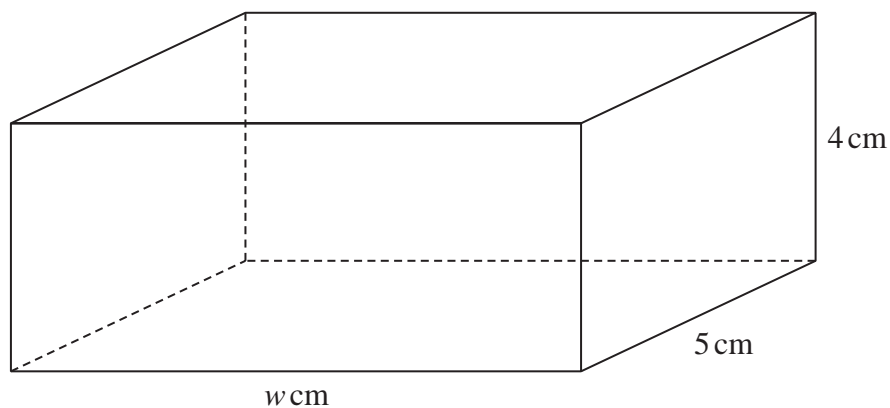

The block has length w cm, width 5 cm and height 4 cm

The density of iron is 7.8 g/cm^3

The mass of the block is 1950 g

Work out the value of w

$$w = \dots\dots\dots$$

(Total for Question 11 is 3 marks)

DO NOT WRITE IN THIS AREA

DO NOT WRITE IN THIS AREA

DO NOT WRITE IN THIS AREA



12 Moeen has a biased 6-sided dice.

The table gives information about the probability that, when the dice is thrown, it will land on each number.

Number	1	2	3	4	5	6
Probability	x	0.15	0.5	y	0.13	0.03

(a) Show that $x + y = 0.19$

(2)

Given that $3x - y = 0.09$

and $x + y = 0.19$

(b) work out the value of x and the value of y
Show clear algebraic working.

$x = \dots\dots\dots$

$y = \dots\dots\dots$

(3)

(Total for Question 12 is 5 marks)

DO NOT WRITE IN THIS AREA

DO NOT WRITE IN THIS AREA

DO NOT WRITE IN THIS AREA



DO NOT WRITE IN THIS AREA

DO NOT WRITE IN THIS AREA

DO NOT WRITE IN THIS AREA

13 Novak is going to play two games of tennis.

The probability that he wins the first game is 0.7

If he wins the first game, the probability that he wins the second game is 0.9

If he loses the first game, the probability that he wins the second game is 0.4

(a) Complete the probability tree diagram.

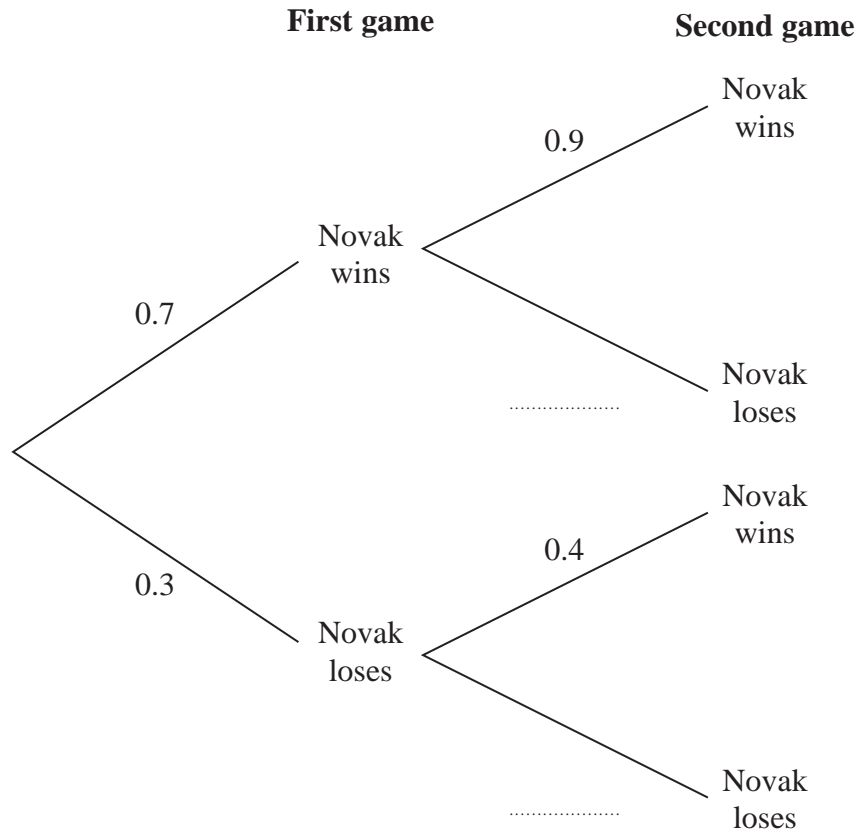

(1)

(b) Work out the probability that Novak wins both games of tennis.

.....
(2)

(Total for Question 13 is 3 marks)



P 7 2 7 9 2 A 0 1 3 2 8

14 The table gives information about the times taken by 80 people to run a race.

Time taken (t minutes)	Frequency
$50 < t \leq 60$	15
$60 < t \leq 70$	16
$70 < t \leq 80$	21
$80 < t \leq 90$	14
$90 < t \leq 100$	8
$100 < t \leq 110$	6

(a) Complete the cumulative frequency table.

Time taken (t minutes)	Cumulative frequency
$50 < t \leq 60$	
$50 < t \leq 70$	
$50 < t \leq 80$	
$50 < t \leq 90$	
$50 < t \leq 100$	
$50 < t \leq 110$	

(1)

DO NOT WRITE IN THIS AREA

DO NOT WRITE IN THIS AREA

DO NOT WRITE IN THIS AREA



DO NOT WRITE IN THIS AREA

DO NOT WRITE IN THIS AREA

DO NOT WRITE IN THIS AREA

(b) On the grid below, draw a cumulative frequency graph for your table.

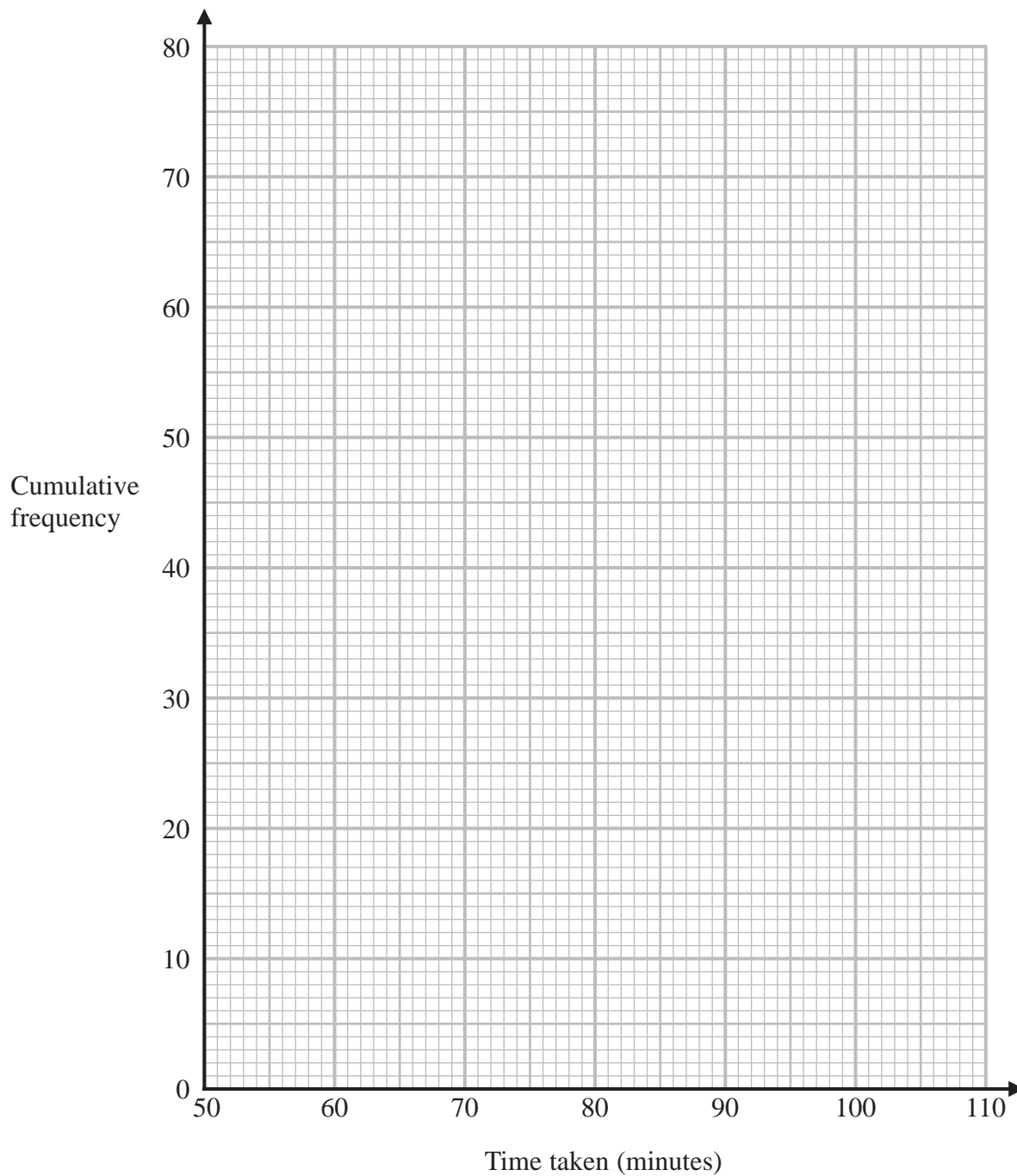

(2)

(c) Use your graph to find an estimate for the median time taken.

..... minutes
(1)

(d) Use your graph to find an estimate for the interquartile range of the times taken.

..... minutes
(2)

(Total for Question 14 is 6 marks)



15

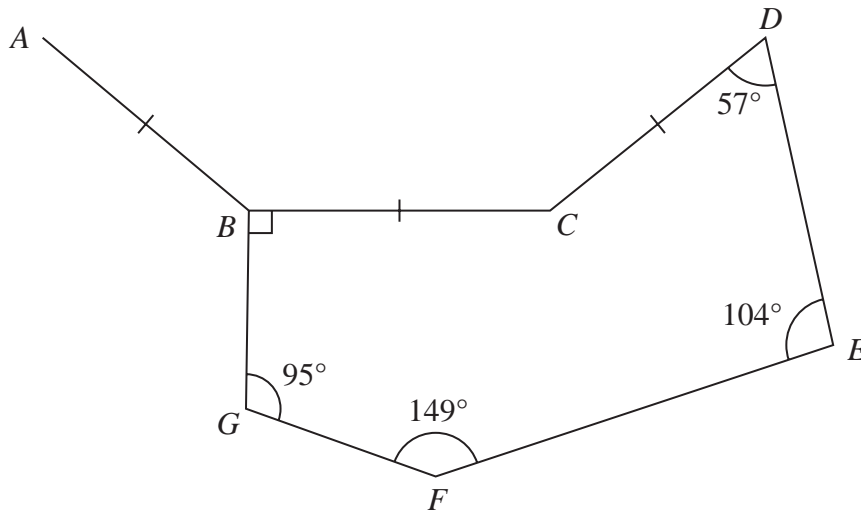

Diagram **NOT** accurately drawn

DO NOT WRITE IN THIS AREA

DO NOT WRITE IN THIS AREA

DO NOT WRITE IN THIS AREA

$BCDEFG$ is a hexagon.
 AB , BC and CD are three sides of a regular n -sided polygon.

Calculate the value of n
 Show your working clearly.

$n = \dots\dots\dots$

(Total for Question 15 is 4 marks)



16 Use algebra to show that $0.1\dot{7}\dot{6} = \frac{35}{198}$

(Total for Question 16 is 2 marks)

17 F is inversely proportional to the square of r

$$F = 36 \text{ when } r = 4$$

(a) Find a formula for F in terms of r

.....
(3)

(b) Work out the value of F when $r = 48$

.....
(1)

(Total for Question 17 is 4 marks)



P 7 2 7 9 2 A 0 1 7 2 8

18 Diego builds a fence using fence panels.

The total length of the fence is 50 metres, correct to the nearest 5 metres.
The length of each fence panel is 1.3 metres, correct to the nearest 10 cm.

The cost of each fence panel is £8.65

Diego may only buy complete fence panels.

Diego only pays for the number of panels he needs to build the fence.

Work out the greatest difference in the possible amounts that Diego could pay to build the fence.

Show your working clearly.

DO NOT WRITE IN THIS AREA

DO NOT WRITE IN THIS AREA

DO NOT WRITE IN THIS AREA

£.....

(Total for Question 18 is 4 marks)



- 19 The diagram shows a triangle ABC where A , B and C represent the positions of three towns.

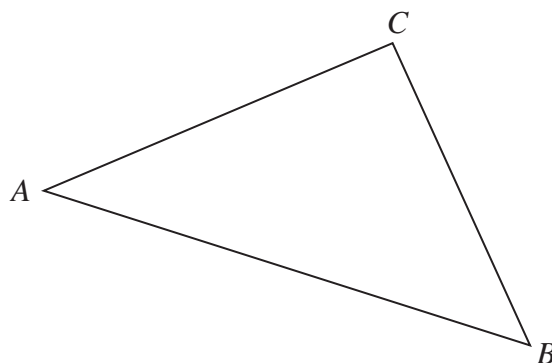

Diagram **NOT**
accurately drawn

$$\vec{AB} = \begin{pmatrix} 7 \\ -2 \end{pmatrix} \quad \vec{BC} = \begin{pmatrix} -3 \\ 5 \end{pmatrix}$$

Pru travels directly from A to B and then directly from B to C

Yang travels directly from A to C

Given that the values for \vec{AB} and \vec{BC} are in kilometres,

work out how much further Pru travels than Yang travels.

Give your answer in km, correct to one decimal place.

..... km

(Total for Question 19 is 5 marks)



20 Curve **C** has equation $y = f(x)$

The graph of curve **C** has one maximum point.

The coordinates of this maximum point are (3, 5)

(a) Write down the coordinates of the maximum point on the curve with equation

(i) $y = 2f(x)$

(.....,)
(1)

(ii) $y = f(x) - 7$

(.....,)
(1)

(iii) $y = f(-x)$

(.....,)
(1)

Curve **L** has equation $y = x^2 + 7x + 20$

Curve **L** is transformed to curve **S** under the translation $\begin{pmatrix} 2 \\ 0 \end{pmatrix}$

(b) Find an equation for **S**

Give your answer in the form $y = ax^2 + bx + c$

$y = \dots\dots\dots$
(4)

(Total for Question 20 is 7 marks)

DO NOT WRITE IN THIS AREA

DO NOT WRITE IN THIS AREA

DO NOT WRITE IN THIS AREA



21 The curve **T** has equation $y = x^3 - 2x^2 - 9x + 15$

(a) Find $\frac{dy}{dx}$

$$\frac{dy}{dx} = \dots\dots\dots$$

(2)

(b) Find the range of values of x for which **T** has a positive gradient.
Give your values correct to 3 significant figures.
Show your working clearly.

.....

(4)

(Total for Question 21 is 6 marks)

DO NOT WRITE IN THIS AREA

DO NOT WRITE IN THIS AREA

DO NOT WRITE IN THIS AREA



P 7 2 7 9 2 A 0 2 1 2 8

22 Some people attend a concert.

The histogram shows information about the ages of these people.

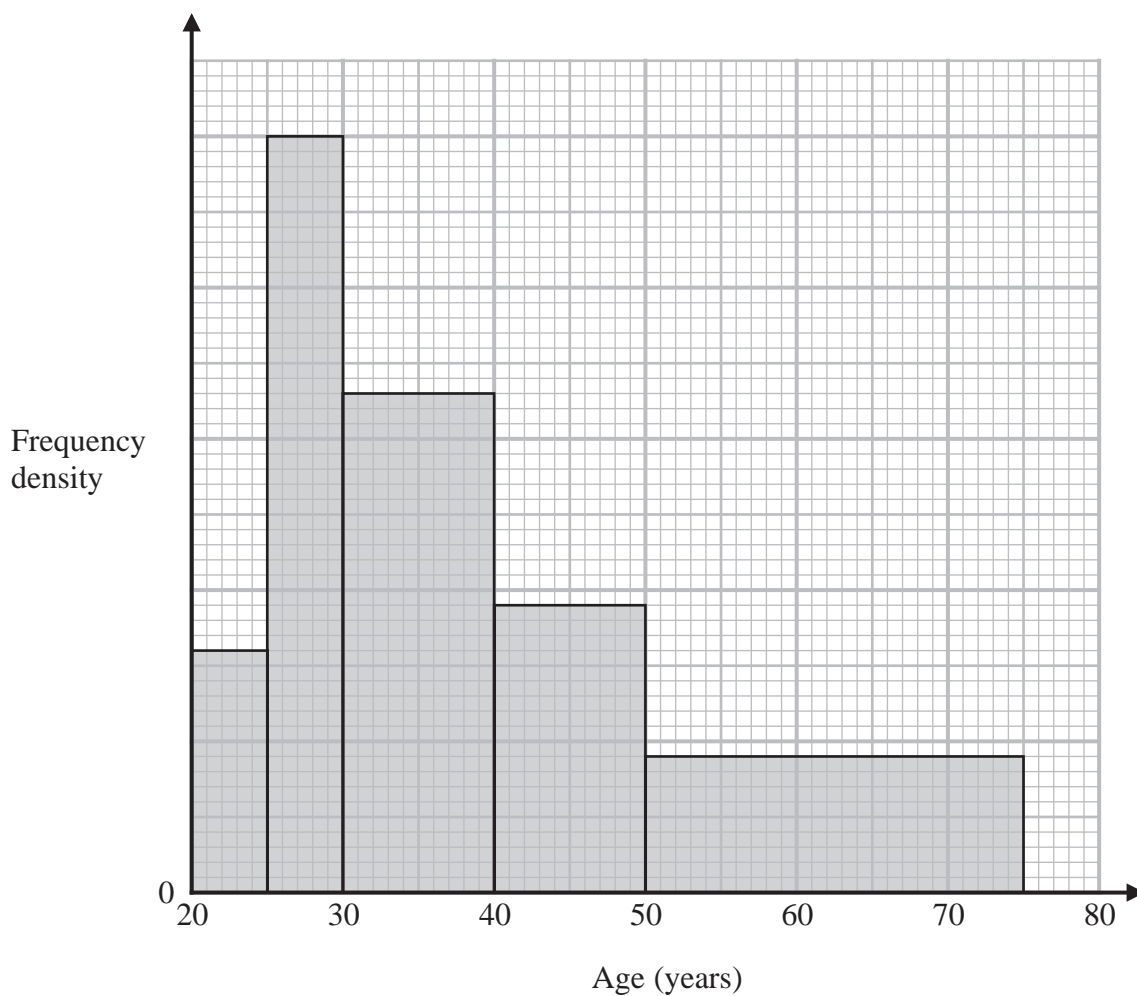

Work out an estimate for the percentage of these people who are aged more than 55 years.

Give your answer correct to one decimal place.

DO NOT WRITE IN THIS AREA

DO NOT WRITE IN THIS AREA

DO NOT WRITE IN THIS AREA



DO NOT WRITE IN THIS AREA

DO NOT WRITE IN THIS AREA

DO NOT WRITE IN THIS AREA

.....%

(Total for Question 22 is 4 marks)

Turn over for Question 23



23 Simplify $(x^2 - 4) \div \left(\frac{4x^2 - 7x - 2}{x} \right) - 2x$

Give your answer in the form $\frac{ax^2}{bx + c}$ where a , b and c are integers.

DO NOT WRITE IN THIS AREA

DO NOT WRITE IN THIS AREA

DO NOT WRITE IN THIS AREA

(Total for Question 23 is 4 marks)



24 Given that

$$2^n = 2^{x^2} \times 16^x \times 8$$

and

$$x > 0$$

find an expression for x in terms of n

State any restrictions on n

DO NOT WRITE IN THIS AREA

DO NOT WRITE IN THIS AREA

DO NOT WRITE IN THIS AREA

(Total for Question 24 is 5 marks)



P 7 2 7 9 2 A 0 2 5 2 8

25 Here is a triangle ABC

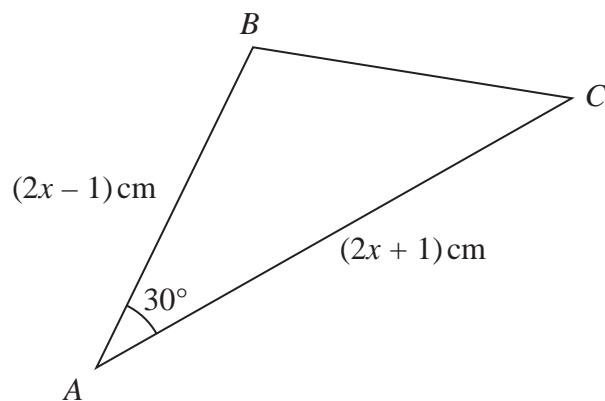

Diagram **NOT**
accurately drawn

DO NOT WRITE IN THIS AREA

DO NOT WRITE IN THIS AREA

DO NOT WRITE IN THIS AREA

The area of the triangle is $(x^2 + x - 3.75) \text{ cm}^2$

Find the size of the largest angle in triangle ABC

Give your answer correct to the nearest degree.



DO NOT WRITE IN THIS AREA

DO NOT WRITE IN THIS AREA

DO NOT WRITE IN THIS AREA

(Total for Question 25 is 6 marks)

TOTAL FOR PAPER IS 100 MARKS



DO NOT WRITE IN THIS AREA

DO NOT WRITE IN THIS AREA

DO NOT WRITE IN THIS AREA

BLANK PAGE

